

ERIKS

ERIKS

ERI

**SIMONA**

RIKS

ERIKS

ERIKS



ERIKS

ERIKS

ERI

Processing instructions

02/2004 Lining and Composite Construction

RIKS

ERIKS

ERIKS

## Contents

<b>1</b>	<b>General</b> .....	<b>2</b>
1.1	Criteria for Selecting Internal Liner Materials .....	2
1.2	Loose Shirt Lining .....	2
1.3	Bonding agent .....	3
<b>2</b>	<b>Range of products and requirements</b> .....	<b>4</b>
2.1	Sheets .....	5
2.2	Pipes .....	6
2.3	Other materials for composite systems .....	6
<b>3</b>	<b>Technical information</b> .....	<b>7</b>
3.1	Overview .....	7
3.2	Bond strength criteria .....	8
3.2.1	Traction-adhesive strength test .....	8
3.2.2	Shear test .....	8
3.2.3	Peel test .....	9
3.2.4	Annular or segmental shear test .....	9
<b>4</b>	<b>Processing and using liner sheets</b> .....	<b>11</b>
4.1	Gluing PVC .....	11
4.2	Thin liners .....	11
4.3	Service at high temperatures .....	12
<b>5.</b>	<b>Liner materials in service</b> .....	<b>14</b>
5.1	Composite designs .....	14
5.2	Liners .....	15
5.3	Acceptance tests .....	18
5.3.1	Bond strength .....	18
5.3.2	Welded seam permeability .....	18
<b>6</b>	<b>Advice and information</b> .....	<b>20</b>
<b>7</b>	<b>Literature</b> .....	<b>21</b>

## 1 General

### 1.1 Criteria for Selecting Internal Liner Materials

In recent years composite designs have become increasingly important in chemical engineering and pipeline construction. Wherever solid plastic designs or stainless steel and special metals are confronted with economic limitations related to design, it is preferable to use a composite design with an internal liner. The high chemical resistance of thermoplastics from the SIMONA range of products is complemented by the physical strength of proven materials such as GRP and steel.

One of the most important criteria for selecting an internal liner is the chemical resistance to the media used. For details, please refer to our SIMCHEM CD. Alternatively, please feel free to call us for further information.

**Table 1: Material specifications of SIMONA®**

#### Thermoplastics

SIMONA® material	Coefficient of linear thermal- expansion	Physiological admissibility
	mm/m/°C	
PVC-CAW	0.08	–
PVC-MZ	0.10	–
PE-HWU	0.18	BgVV <sup>1</sup>
PP-DWU	0.16	FDA <sup>2</sup>
PP-C		–
PP-EL		–
PVDF	0.13	FDA <sup>2</sup>
PVDF-C	0.14	DGCCTF <sup>3</sup>
E-CTFE	0.05	BgVV <sup>1*</sup>

<sup>1</sup> BgVV: complies with Recommendation III of the Federal Institute for Consumer Health Protection and Veterinary Medicine (187th bulletin issued by the Federal Health Office, Sheet 34, 296 (1991)).

\* For E-CTFE: currently being drafted

<sup>2</sup> FDA: complies with Food and Drug Administration (CFR 21, part 177.1520)

<sup>3</sup> DGCCTF: complies with Direction Générale de la Concurrence, de la Consommation et de la Répression des Fraudes (O. J. No. 1227/90 ff.)

Other criteria are service temperature range, fabrication technology, usage in the food sector, and possible thermal change in length.

Please remember that the service temperature range of the internal liner may be different from that of the pure thermoplastic (see para. 4.3). This particularly applies to fluoropolymers used as internal liners.

### 1.2 Loose Shirt Lining

This system solution, which in actual fact is not a lining or composite construction, ought to be mentioned briefly here for the sake of completeness.

Loose Shirt Lining is a system where a container made of thin-walled chemically resistant material is loosely placed in a container made of low-cost material. The outer, possibly cross-ribbed container provides the physical strength.

Generally speaking, this system is limited to applications implemented at room temperature. Because outer and inner containers are not firmly connected to one another, the inner container may develop a bulge at relatively high temperatures on account of linear expansion. This can also cause the system to fail, depending on the level of temperature.

There are also limits to the dimensions of the containers: if the container is too large, care must be taken to ensure that the emptied inner container does not collapse inwards owing to the thin wall. This can, for example, be achieved by using so-called anchor ties, which keep the walls apart like supporting braces. Another option would be to use channels, which are placed over the top edges of the outer and inner containers in such a way that the inner container cannot bulge inwards at the upper edge.

One example of an application of this system is in tank repair.

### 1.3 Bonding agent

PE, PP, PVDF, and E-CTFE – as opposed to PVC – cannot be dissolved by polyester, epoxy, polyurethane, or furan resins used in GRP processing. Without pre-treatment it is impossible to achieve a durable bond or coating or directly apply solidifying resins. For this reason SIMONA offers the following sheets and pipes with various bonding-agent systems for use in composite construction:

- Thermoplastic polyester fabric (SK) for polyolefins and PVDF
- Glass fabric for E-CTFE and as a special finish for PE, PP, and PVDF
- PP fabric for PP-C
- Chemical pre-treatment (CV) only for PVDF pipes

The glass or stretch fabric is firmly anchored in the liner material at high temperature during the production process, completely covering the full area of the treated sheet side.

However, this type of backing is not possible in pipe extrusion. The thermally after-treated and thus low-stress SIMONA® PP and PVDF liner pipes can be laminated if they have been pretreated by the customer. The liner pipe placed on a mandrel is heated by a flame. Glass fabric or fibres are embedded into the melted outer surface of the pipe manually or automatically. When it has cooled down the prepared liner pipe is laminated by the usual methods.

Furthermore, you can procure PVDF pipes with a chemically pretreated surface, which is suitable for

direct lamination. These pipes (PVDF-CV) are also subjected to thermal after-treatment. To achieve successful coating/lining, it is necessary to ensure that the surfaces of the liner and the liner pipe are free of grease, dirt, and dust. This can be achieved by rubbing down with cellulose non-woven wipes soaked in solvent (acetone, spirits, methylene chloride).

## 2 Range of Products and Requirements

Liner materials supplied by SIMONA meet the requirements of the chemical industry for thermoplastic liners; the semi-finished products are produced in accordance with or on the basis of the following DIN standards (see section 7) (see Table 2).

At present, there are no pertinent recommendations for the fluoropolymers PVDF and E-CTFE. SIMONA therefore produces semi-finished products from these materials based on the standards mentioned.

In DIN 28055, Part 1, a lining thickness of 3 mm thermoplastic is specified for components made of metal materials. For polyolefins and PVC types it is customary to use liner materials which are 4 mm (to 5 mm)

thick, thus meeting the requirements, if practicable, of BS 6374, Part 1, which specifies maximum thermoplastic thickness. According to BS 4994, the lining thickness should not be below 2.5 mm for PVC. As regards sheet thicknesses above 4.5 mm and a service temperature above 40 °C, this standard cites potential disruptions to operations. For other thermoplastic materials the liner thickness has to be at least 2.0 mm.

With regard to pipes made of glass-fibre reinforced polyester resins with a thermoplastic internal liner, DIN 16965, Part 2, specifies a minimum wall thickness of 4 mm for polyolefin and PVC pipes (from d = 90 mm) and 3 mm for PVDF pipes (from d = 63 mm).

**Table 2: Main standards for the production of semi-finished products**

	<b>PVC-CAW</b> <b>PVC-MZ</b>	<b>PE-HWU-SK</b>	<b>PP-DWU-SK</b> <b>PP-C-PK</b> <b>PP-B liner pipe</b>	<b>PVDF-SK</b> <b>PVDF-GK</b> <b>PVDF-CV liner pipe</b>	<b>E-CTFE-GK</b>
Moulding	DIN EN ISO 1163-1	DIN EN ISO 1872	DIN EN ISO 1873	Kynar	Halar
Dimensions (pipe)	-	-	8077	Based on ISO 10931	Based on ISO 10931
Quality requirement (pipe)	8062	8075	8078	-	-
Technical terms of supply (sheet)	16927	DIN EN ISO 14632	DIN EN ISO 15013	Based on DIN EN ISO 14632	Based on DIN EN ISO 14632

## 2.1 Sheets

**With regard to the liner thicknesses mentioned for backed products, residual wall thickness is equal to nominal thickness.**

The dimensions available are listed in detail in our brochure entitled "Sheets, Rods, Profiles and Welding Rods".

We will be pleased to advise you on current details of all materials.

Note:

Processing thin liner materials requires special care and calls for a high level of manual skill acquired by long-term practice (see also para. 4.2).

**Table 3: Polyolefins (PE, PP)**

Products	PE-HWU-SK	PP-DWU-SK	PP-C-PK	PVC-CAW	PVC-MZ
<b>Sheets</b>	2000 x 1000 3-5	2000 x 1000 3-6	2000 x 1000 3-6	2000 x 1000 0.8-30	2000 x 1000 0.8-30
	3000 x 1470 3-5	3000 x 1500 3-6	3000 x 1500 3-6	3000 x 1500 1.5-20	3000 x 1500 1.5-20
	20000 x 1470 3-5	20000 x 1500 3-5	20000 x 1500 3-5	2440 x 1220 1-25	

Nominal wall thickness equals residual wall thickness

**Special types** PP-EL-SK electrically conductive polypropylene, stretch-backed

**Table 4: High-performance materials (PVDF, E-CTFE)**

Products	PVDF-SK	E-CTFE-GK	PVDF-GK
<b>Sheets</b>	2000 x 1000 2-6	2000 x 1000 1.5-4	2000 x 1000 2-6
	3000 x 1500 2-5	10000 x 1000 2.3-4	
	20000 x 1500 2-5	20000 x 1000 2.3-4	

Nominal wall thickness equals residual wall thickness

**Special types** PVDF-C-SK copolymer polyvinylidene fluoride, stretch-backed

Sheets: length x width x thickness · All dimensions stated are in mm · In some cases minimum quantities are required for production · Other special types are available on request

## 2.2 Pipes

SIMONA® PP-B liner pipes (Type 2) with diameter d 32–400, SIMONA® PVDF-CV liner pipes with diameter d 32–400 available on request. The dimensions available are listed in our catalogue entitled "Pipes and Fittings". Low-stress due to thermal after-treatment; standard length 5 m, lengths up to 6.2 m are available as custom products

## 2.3 Other Materials for Composite Systems

In addition to the standard types for composite systems described here in greater detail, there are other materials available on request (e.g. PVDF-EL-SK, PVDF-EL-CV pipes, etc.) using a backing system. However, we must point out that a change in pull-off values compared to standard types should be expected with regard to these special types.

## 3 Technical Information

### 3.1 Overview

SIMONA® liner materials offer a high level of security for composite construction on account of excellent resin adhesion, particularly in the case of:

- PVC, due to direct lamination after appropriate surface cleaning
- PE, PP, PVDF, and E-CTFE, due to the solid bond of the fabric within the base material
- PVDF-CV pipes, due to direct lamination to the chemically pretreated surface

Special properties of polyester backing (SK):

- Excellent three-dimensional stretching, therefore thermoforming and fabrication of dished ends is feasible.
- Thermoplastic stretch fabric must be neatly finished, particularly at the edge, in order to prevent welding defects.
- Polyester fabric is susceptible to hydrolysis. Consequently, this fabric is only suitable up to temperatures of 80 °C. In the case of slightly diffusing media, please consult our Applications Technology Department.

Special properties of glass backing (GK):

- This is a glass fabric. As a result, three-dimensional thermoforming (e.g. dished end) is feasible.
- Resistant to hydrolysis because the fabric is inorganic (exception: hydrochloric acid at relatively high temperatures, hydrofluoric acid).
- Localised finishing of the fabric around the welded seam is necessary in order to avoid welding defects.

Special properties of polypropylene backing (PK):

- Available for PP-C material
- Available as a fabric which allows excellent three-dimensional thermoforming
- Resistant to hydrolysis
- Chemical resistance is identical to that of PP sheet, which is why it is possible to achieve a longer service life for the composite in the case of highly permeating media
- It is not necessary to finish the fabric at the welded zones

Special properties of the chemically pretreated surface:

- For SIMONA® PVDF pipes
- It is not necessary to finish the CV layer at the welding zones
- Surface is easy to clean with soft brushes (mechanically) and acetone or high-purity spirits
- The composite has better chemical resistance because the chemically pretreated surface is resistant to hydrolysis

## 3.2 Bond Strength Criteria

As opposed to a composite design of PVC-GFK (direct lamination) the strength of liner materials requiring a backing system depends on the anchorage of the fabric within the thermoplastic.

Information about the quality of a composite is provided by various test methods such as:

- Traction-adhesive strength test      DIN 53766 Part 1
- Shear test                      ISO 14130  
    BS 4994  
    DIN 65148
- Peel test                         BS 4994  
    NF T 57-900
- Annular or segmental shear strength      DIN 53769 Part 1

Within the scope of quality assurance we check the bond strength of our liner materials at room temperature: pull-off strength for sheet material and shear strength for SIMONA® PVDF-CV liner pipes. We supplement our range of tests with periodic measurements at high temperatures as well as peel tests and shear strength tests. The bond strengths stated in the tables below are **average values** which are based on the internal investigations indicated.

To the processor and user this information indicates the potential fields of application of the various types of liner. At the same time it shows that high bond strengths are possible, thus providing the finished structure with a long service life.

### 3.2.1 Traction-adhesive strength test

(based on DIN 53766 Part 1)

The minimum bond strength between the lining material and the supporting laminate is generally regulated in company standards by the processor or client. For minimum levels of bond strength in the pull-off test it is possible to assume the following approximate figures for guidance only:

- PVC/GF-UP      7 N/mm<sup>2</sup>
- PVDF/GF-UP    5 N/mm<sup>2</sup>
- PP/GF-UP       3,5 N/mm<sup>2</sup>
- PE/GF-UP       2,5 N/mm<sup>2</sup>

**Table 5: Traction-adhesive strength** Averages in N/mm<sup>2</sup> (derived from our own monitoring system)

Palatal A 410	23°C	50°C	80°C	100°C
PE-HWU-SK	3.5	3	-	-
PP-C-PK/PP-DWU-SK	4.5	4	3	-
PVC-CAW/MZ	10	8	-	-
PVDF-SK	7	5	4	3
E-CTFE-GK	7	6	4	3

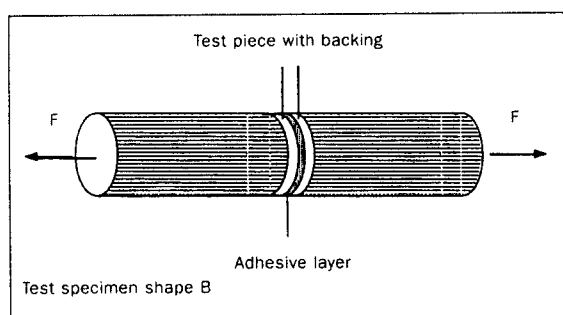

Fig. 1

### 3.2.2 Shear test

(in accordance with BS 4994/based on DIN 65148)

In order to size and design containers and tanks made of reinforced plastic, a minimum bond strength of 7.0 N/mm<sup>2</sup> is specified for the GF-UP/VE composite (glass filament mat) with thermoplastics at room temperature (BS 4994).

**Table 6: Shear strength** Averages in N/mm<sup>2</sup>  
(derived from our own monitoring system)

Palatal A 410	23°C	50°C	80°C	100°C
PP-C-PK/PP-DWU-SK	7	5	4	-
PVC-CAW/-MZ	11	9	-	-
PVDF-SK	11	8	7	4
E-CTFE-GK	10	7	5	3

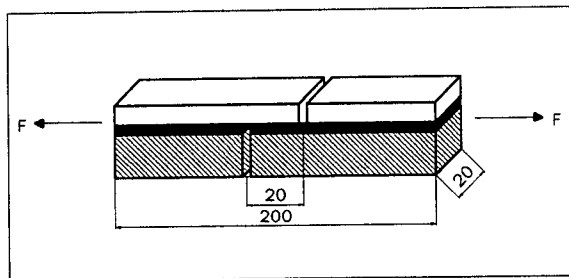

Fig. 2

### 3.2.3 Peel Test

(based on BS 4994 and NF T 57-900)

The French standard NF T 57-900 "Réservoirs et appareils en matières: Code de construction" specifies, as does the British standard BS 4994, a minimum peel strength of 5 N/mm.

**Table 7: Peel strength** Averages in N/mm  
(derived from our own monitoring system)

Palatal A 410	20°C	50°C	80°C	100°C
PP-DWU-SK	10	6	3	-
PP-C-PK	13	8	4	-
PVC-CAW/-MZ	15	10	-	-
PVDF-SK	15	10	7	4
E-CTFE-GK	17	13	8	5

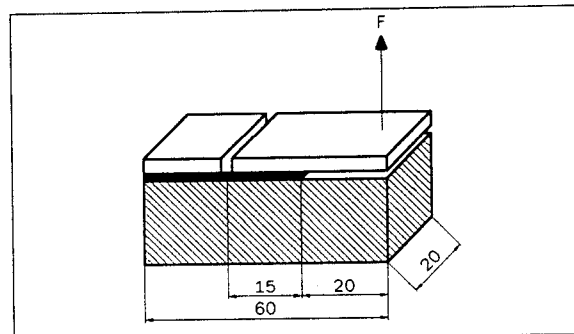

Fig. 3

### 3.2.4 Annular or Segmental Shear Test

The bond strength of SIMONA® PVDF-CV liner pipes and the resin coat is determined by establishing the bond shear strength in accordance with DIN 53769, Part 1. This method can be applied to determine the load-bearing capacity of a (pipe) composite when subjected to thermal stress and thermal cycling. For pipes up to DN 90, the investigation is performed by means of the annular shear test. Figure 4 characterises the segmental shear test for pipes with an outside diameter  $d > 90$  mm.

**Table 8: Annular/segmental shear strength**

Averages in N/mm<sup>2</sup>

Palatal A 410	20°C	50°C	80°C
PVDF-CV pipe	8	6	4

For wrapped GF-UP tube with SIMONA® PVDF-CV liner pipe, the minimum shear strength of 5 N/mm<sup>2</sup> required by DIN 16964 is surpassed at room temperature. This also applies to laminates with different types of resin, as measurements on a composite pipe made of SIMONA® PVDF-CV liner pipe (OD = 125 mm,  $e = 3$  mm) have shown.

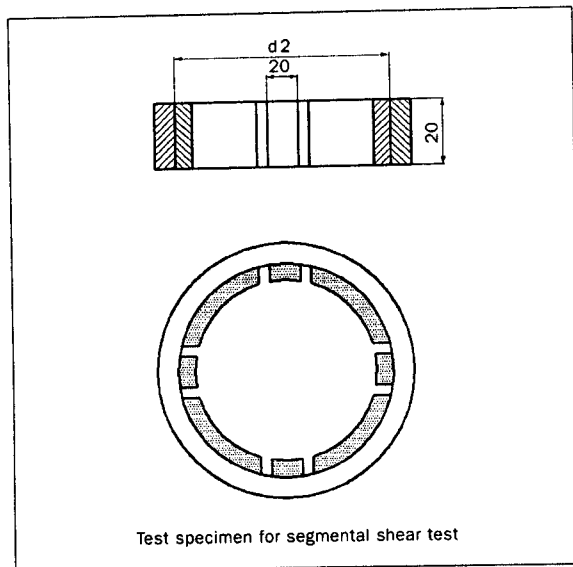

Fig. 4

As analyses conducted by SIMONA have demonstrated, different resins can have different bond strengths even if they belong to the same chemical group (e.g. different polyester resins). However, all resins tested by SIMONA have satisfied the minimum requirements.

Often high levels of bond strength go hand in hand with a higher price for resin. The decision as to which resin system will ultimately be used for an application is also a question of expenditure and hence a decision to be taken by the operator or user.

Apart from chemical attack, the performance of a composite design is often influenced by negative pressure and frequent changes in temperature. Void-free processing is extremely important to ensure that the composite system can be used successfully for many years.

## 4 Processing and Using Liner Sheets

Information about processing, particularly welding, thermoforming, and gluing has been provided in the respective product and processing-related publications. In addition, there are other items of interest concerning the processing of liner sheets.

### 4.1 Gluing PVC

Before gluing with epoxy, polyurethane, or unsaturated polyester resins, it is usually recommended that the rigid PVC be roughened in order to increase surface area.

In general, this process causes the thin PVC flash/bristles to “fold over” during further processing and when resin is being applied. Thus, part of the surface is not available for bonding purposes. However, SIMONA tests and research conducted with adhesive manufacturers and processors have indicated that it is advisable to simply wipe down the semi-finished products with a clean cloth. If there is justified suspicion that the surface is contaminated with organic residues (e.g. grease), it can be washed down briefly with acetone or methylene chloride.

### 4.2 Thin Liners

The cost of GRP internal liner tanks and lined steel tanks may be considered an important factor for the purchasing department. This cost is associated with the considerable technical and manual effort or the expensive internal liner. Especially in the case of fluoroplastics it is common practice to make the liner thinner for reasons of cost. This measure increases the risks in processing and service, possibly resulting in a premature failure of a structure, thus necessitating additional expenditure (Table 9).

In order to supplement the existing specifications for thermoplastic liners (para. 2), the following minimum liner thicknesses should be observed:

- 3 mm for polyolefins and PVC
- 2.3 mm for fluoropolymers

**Table 9: Hazards of using thin liners**

<b>Risk in processing</b>	<b>Risk in service</b>
<ul style="list-style-type: none"> <li>▪ Higher risk of perforation, e.g. due to impact, increases length of welded seam</li> </ul>	<ul style="list-style-type: none"> <li>▪ Higher permeation of medium due to reduced wall thickness and due to welding seam offsets</li> </ul>
<ul style="list-style-type: none"> <li>▪ Increased notch effect around the welded seam</li> </ul>	<ul style="list-style-type: none"> <li>▪ High risk of tension cracks, in the case of media which tend to have an oxidising effect for example</li> </ul>
<ul style="list-style-type: none"> <li>▪ Larger offset at sheet joins due to irregularities in the surface or due to tolerances</li> </ul>	

### 4.3 Service at High Temperatures

The backings on SIMONA® liner sheets also adhere firmly within the base material and supporting laminate at relatively high temperatures (see section 3). In practice the combination of the liner material and backing is affected by many factors and it is therefore possible to state the following upper service temperatures irrespective of the resin system applied:

- PE-HWU-SK                    ≤ 60°C
- PP-C-PK/PP-DWU-SK        ≤ 80°C
- PVDF-SK                     ≤ 90°C
- PVDF-GK/E-CTFE-GK       ≤ 100°C
- PVDF-CV                    ≤ 90°C
- PVDF-CAW/-MZ            ≤ 60°C

Applications with a thermal load which is 10°C to 20°C higher have been identified particularly in the case of fluoroplastics. However, they call for extremely careful consideration and implementation.

When using a thermoplastic liner in the upper temperature range, frequent and rapid temperature changes should be avoided; they may well result in negative effects (delamination) on the composite system.

Although thermoplastics are chemically resistant under certain chemical loads, they are occasionally permeable to low-molecular substances. For solid structures this is negligible. With composite designs, especially in the upper temperature range, the potentially varying permeability of the reinforcing material and liner material should be taken into account because the permeant can attack and destroy both the backing (fabric) and resin system, and ultimately the outer physical protective shell.

For further information on permeation, please refer to the SIMONA SIMCHEM CD under the heading "Basics\Plastics and Chemicals\Behaviour of Plastics\Permeation".

Nevertheless, at this point we would like to briefly summarise some important details of permeation: the driving force behind permeation is the concentration differential of the chemical concerned between the inside and outside of the barrier layer; and it can be divided into 3 stages:

- Dissolving of the permeant within the polymer
- Diffusion through the polymer
- Desorption from the polymer

The total of these 3 stages ultimately makes it possible to state the amount of permeation flow within a certain period. If any of these stages are weakened or prevented, permeation is influenced accordingly.

Permeation is also dependent on temperature and wall thickness. The amount of permeation, examined over the same period, is directly proportional to temperature and indirectly proportional to sheet thickness. In order to largely suppress permeation, the temperature can be lowered and/or the wall thickness of the internal liner can be increased. Increasing wall thickness of the internal liner is only feasible within a small range, mainly because aspects associated with production and processing have to be taken into account.

Specialist literature offers a range of information on permeability of various chemicals and materials. These measurements have generally been taken from thin foils and cannot necessarily be applied to plastics with large wall thicknesses.

As regards the measurements which are referred to in the literature, the three individual permeation stages quoted are generally not impaired or restricted. In the case of composite construction and liners the situation is different if void-free processing can be assumed. Here, at least, the "Desorption from the polymer" stage is influenced by the resin system towards less permeation.

Permeation cannot be completely ruled out, particularly at relatively high temperatures and in the case of chemicals with small molecules. For this reason, we recommend clarifying the resin system for the particular application with the resin manufacturer.

## 5 Liner Materials in Service

In long-term service thermoplastics tend to reduce (inherent) stresses and strains. However, the materials also manifest expansion and creep, particularly when subjected to a (constant) mechanical load. This behaviour is taken into consideration in the design when sizing components.

For large-volume vessels thick thermoplastic walls are calculated. This may frequently result in processing problems, which may lead to high production costs. In the manufacture of chemical apparatus, the cost-efficiency when constructing tanks is significantly improved by combining two or more materials. According to their type of fabrication these are divided into composite designs and liners.

### 5.1 Composite Designs

Composite designs using SIMONA® liner sheets combine high chemical resistance and thermal resistance with the excellent structural properties of polyester resins and epoxy resins.

Examples:

- Laboratory construction:  
Backed PP or PVDF sheets are glued onto wooden boards or chipboards with the aid of two-component adhesive, e.g. polyurethane-based adhesive.
- Composite construction tanks:  
The selection of materials should also take into consideration the criteria described in para. 1.1. After appropriate cleaning, PVC sheets are laminated directly with reaction resins and reinforcement substances (see para. 4.1).

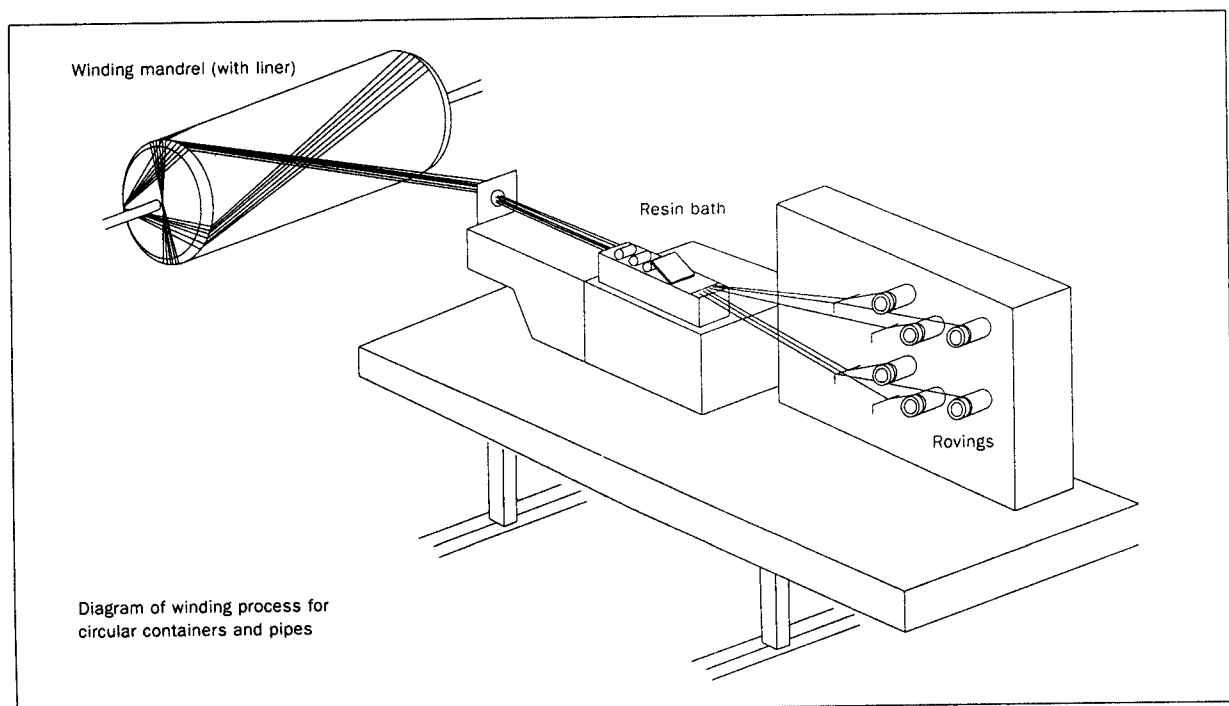

Fig. 5

A composite design of thermoplastic liner and supporting laminates made of glass-fibre reinforced thermoset plastics is particularly suitable for circular containers. After suitable preparation on a winding mandrel the liner sheets/webs are welded to one another, and after attaching a carbon fibre strip for acceptance tests (see para. 5.3) they are laminated "wet on wet" with resin and glass rovings/textiles.

As with circular containers, pipes can also be made with polypropylene or E-CTFE. If the surface to be laminated is not provided with a bonding-agent system, glass textiles are first of all melted, under control, into the surface softened by flaming and fabricated after solidification as shown above. Of the numerous types of resin available and their blends, we have achieved positive levels of bond strength with formulas using the following base resins (see Table 10).

By varying the formula it was possible to selectively obtain certain properties in the supporting laminate or pure resin layer.

When subjected to changes in thermal stress and pressure stress, it is possible to achieve an increase in the impact resistance of the resin used by adding

more flexible types. The first layers are applied with pure Flex resin or a mixture with the resin to be used. One example is Palatal E 200 with its base resin Palatal A 410, which are particularly suitable for bonding to PVC. By adding polymerisation inhibitors, the curing temperature of the supporting laminate can be lowered. This reduces the inherent tension of the resin and enhances the adhesion properties between the liner and the laminate. Moreover, in the event of extreme chemical stress and permeation, it may be necessary to apply a coat of pure resin with defined properties.

## 5.2 Liners

Throughout the history of installation and apparatus engineering steel structures have been used on account of their relatively trouble-free technical implementation, a high degree of structural safety, low-cost material, and low production costs.

In cases of highly corrosive influences the special alloys that can be used are seldom able to satisfy the requirements in terms of cost-effectiveness and method of construction. These issues are addressed by liners with thermoplastics. For many years now,

**Table 10: Resins and their service temperatures**

Trade name	Type	Manufacturer	Max. temperature <sup>1</sup>
Atlac 382	Unsaturated polyester	DSM	Approx. 100°C
Derakane 411	Vinyl ester	Dow Chemicals	Approx. 105°C
Derakane 470	Vinyl ester	Dow Chemicals	Approx. 140°C
Palatal-A 410	Unsaturated polyester	DSM	Approx. 80°C
Atlac 430	Vinyl ester	DSM	Approx. 105°C
Palatal-E 200	Unsaturated polyester	DSM	Room temperature
Sconoran UP-UN 2	Unsaturated polyester	BSL GmbH	Approx. 80°C

<sup>1</sup> derived from manufacturer's specifications

fluoroplastics in particular have proved successful within this field of application.

In the fabrication process the container to be lined is first of all cleaned by carefully removing any rust, oil, grease and other impurities. In the subsequent process the surface is prepared chiefly by (sand) blasting. The appearance of the prepared surface must conform to the reference of Sa 2 1/2–Sa 3.

Information about how to perform this process and assess the surface is provided by ISO 8504, Part 2, ISO 8501, Part 1, and DIN EN ISO 12944, Part 4.

Further requirements for metal surfaces being lined with thermoplastics are listed in DIN standards 28051 and 28053 as well as British standard BS 6374, Part 1.

The adhesive is applied evenly to the prepared joining surfaces with a serrated applicator, taking the pot life into account, and the internal liner also prepared with adhesive is pressed onto the steel surface.

In order to achieve an optimum bond, the internal liner should be pressed onto the steel surface evenly and firmly at all points. This can be performed by applying a vacuum, for example. The diagram below illustrates the principle.

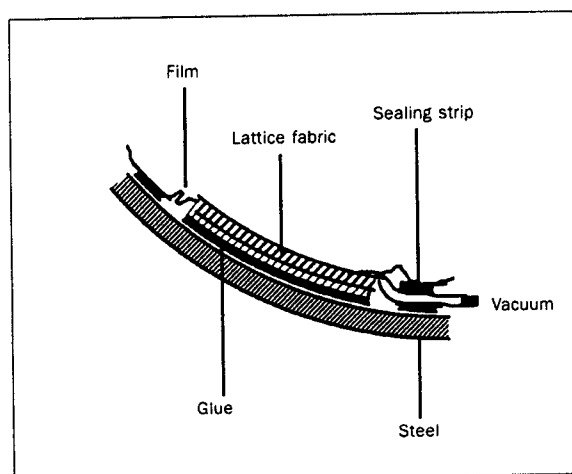

Fig. 6

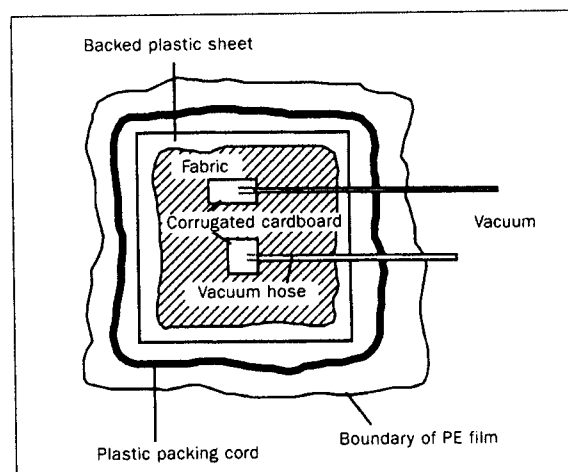

Fig. 7

**Table 11: Epoxy resins and their service temperatures**

Trade name	Type	Manufacturer	Max. temperature <sup>1</sup>
Araldit 2013 (AV 144-2/HV 997)	Epoxy	Ciba-Geigy AG	Approx. 60°C
Araldit AV 4415/Hardener HV 4416	Epoxy	Ciba-Geigy AG	Approx. 180°C
Araldit AW 136H/Hardener HV 997	Epoxy	Ciba-Geigy AG	Approx. 70°C
Araldit AV 138/Hardener HV 998	Epoxy	Ciba-Geigy AG	Approx. 120°C
Araldit 2014 (AW 139/XB5323)	Epoxy	Ciba-Geigy AG	Approx. 120°C

<sup>1</sup> derived from manufacturer's specifications

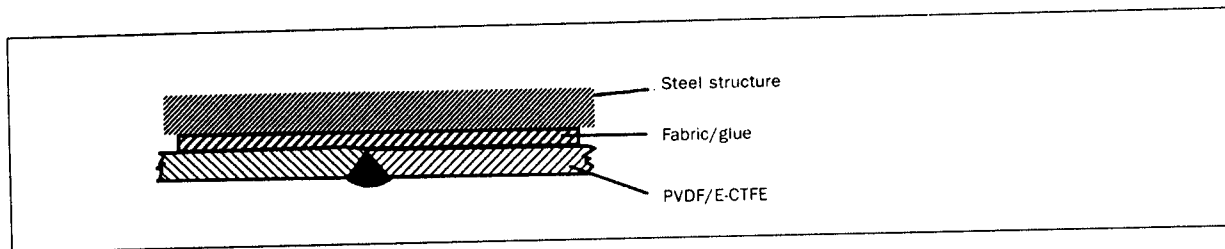

Fig. 8

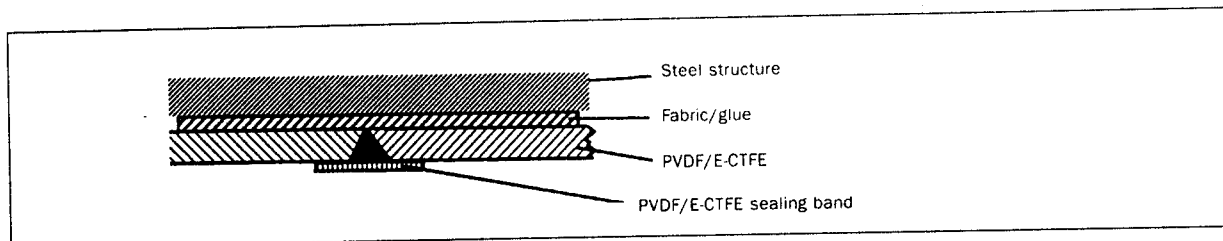

Fig. 9

A jute fabric between the liner and the PE film guarantees complete air extraction and thus uniform contact pressure.

After applying the vacuum there should be a consistent differential pressure of more than 0.8 bar.

Epoxy-based glues are preferred for bonding the liner to the steel. For details about processing and service ranges (e.g. temperature/chemicals), please refer to the information provided by the adhesive manufacturers.

Of the various adhesives and blends available, we have achieved positive levels of bond strength with the formulas in Table 10.

As with resins for composite construction it is possible to find an optimum glue combination by selecting certain criteria – heat, impact stress, chemical resistance, etc.

The amount of glue required is between 0.5 and 2kg/m<sup>2</sup> area, depending on the thickness of coat required.

The sheets (pieces) glued in are cleaned by removing residues of resin at the joins using a V-shaped scraper, and the welded seam is prepared in the same process. Welding has to be performed according to current regulations, e.g. DVS 2207. For further details, please refer to the product information leaflet “Welding” and the product brochures for the respective material.

Cover strips build-up welding, as described in Part 1 of DIN 28055, are designed to protect the (actual hot-gas) welded seam against influence by the media. With a second weld (additional) stresses are introduced to the widened seam zone. Thus, in our opinion, the potential hazard is increased, especially for highly aggressive media that trigger stress cracks. For this reason we believe such a method of making the seam is only appropriate under certain circumstances.

**Note:**

Both the gluing process and the welding of the sheet joints call for considerable experience and should only be performed by trained staff.

### 5.3 Acceptance Tests

In order to establish whether the container is fit for service, various tests are conducted, for example in compliance with DIN 28055, Part 2. For composite designs and liners with thermoplastic liners two tests are particularly important:

1. Strength of bond with the resin/glue system
2. Welded seam permeability.

#### 5.3.1 Bond Strength

In this case, in parallel with the construction of the tank, samples are made or specimens are taken, for example from flange nozzle ports on the finished tank, and tested as described in section 3.2.

#### 5.3.2 Welded Seam Permeability

In the case of non-conductive materials the testing of liner and welding seam permeability is usually conducted by the spark induction method at room temperature. Test apparatuses with a pulsed, rectified high voltage have proved to be particularly non-invasive as regards materials.

With composite designs, carbon fibre strips, which can be obtained from the Schlösser & Cramer company in Wuppertal for example, are introduced to the first layer of resin. For test purposes the strip should be earthed, but this is unnecessary for liners on steel and concrete tanks.

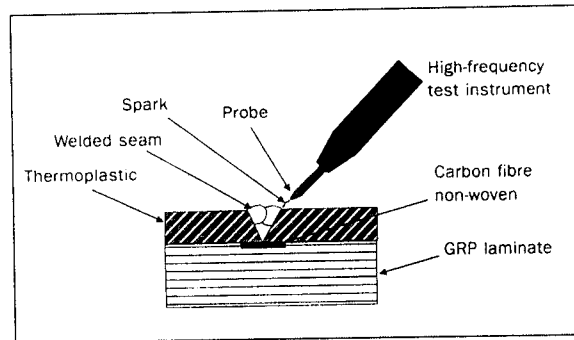

Fig. 10

When performing the spark induction test, the test result is affected not only by the ambient conditions but also especially by the choice of electrodes and test velocity.

From current experience, cracks, voids, and irregularities in the welded seam zone can be found at velocities of between 20 and 40 cm/sec. Dwelling at one spot must be avoided, as must repeated testing of a welded seam within a short space of time because this procedure can reduce the performance of the liner.

The selection of test voltage is of special importance, and it should be matched to the wall thickness of the polymer.

**Table 12: Dielectric strength ( $E_d$ ) of SIMONA plastics**

Material	$E_d$ (kV/mm)
	Measured on sheets 1 mm thick
PE-HWU	47
PP-DWU	58
PVC-CAW	39
PVC-MZ	34
PVDF	25

In older publications the test voltage stated is normally 5 kV/mm liner thickness. High-frequency electric fields exert an influence on the dielectric properties of polymers.

Halogenated plastics, particularly PVDF, therefore react more sensitively to applied high-voltage fields (see Table 12) than polyolefins. Test voltage should therefore be **between 3 and 4 kV/mm** liner thickness and should not be exceeded. Voltage losses in the dielectric air are eliminated by contact with the plastic surface.

Note:

Repeated spark induction tests, particularly in the case of liner materials which have already been in service, tend to reduce dielectric strength – they should be avoided. Dielectric strength can also be reduced by absorbed medium. It is urgently recommended that the liner be dried prior to conducting the test.

## 6 Advice and Information

Our members of staff in Sales and the Applications Technology Department have many years of experience when it comes to applying and processing semi-finished thermoplastic products. We look forward to advising you.

In this connection we would like to draw your attention to the fact that processing assistance described in this publication is by no means complete. It goes without saying there are also other lining methods in use at present; the "vacuum method" described in this document is state-of-the-art.

The listed resin/glue mixtures and bond strength data are for general information only. Therefore, this data cannot be used for every application.

## 7 Literature

1. ISO 8501 Part 1 (12/88) Preparation of steel substrates before application of coating materials; visual assessment of surface cleanliness  
Degrees of rust and degrees of surface preparation for uncoated steel substrates and steel substrates after complete removal of existing coatings
2. ISO 8504 Preparation of steel substrates before application of coating materials, methods of surface preparation
  - Part 1 (03/00) General principles
  - Part 2 (03/00) Blasting
  - Part 3 (08/93) Surface preparation with hand tools and with machine-driven tools
3. ISO 10931 Plastic piping systems for industrial applications – polyvinylidene fluoride (PVDF)
  - Part 1 (02/97) General
  - Part 2 (02/97) Pipes
4. ISO 14130 (12/97) Fibre-reinforced plastics – determination of apparent interlaminar shear strength by the three-point method with a short beam
5. DIN EN ISO 1163 Plasticizer-free polyvinyl chloride mouldings
  - Part 1 (10/99) Designation system and basis for specifications
  - Part 2 (10/99) Preparation of test specimens and determination of Properties
6. DIN EN ISO 1872 Polyethylene mouldings
  - Part 1 (10/99) Designation system and basis for specifications
7. DIN EN ISO 1873 Polypropylene (PP) mouldings
  - Part 1 (12/95) Designation system and basis for specifications
  - Part 2 (12/00) Preparation of test specimens and determination of properties
8. DIN EN ISO 12944-4 (07/98) Corrosion protection for steel structures with coating systems – types of surfaces and surface preparation.
9. DIN EN ISO 14632 (05/99) Extruded sheets made of polyethylene (PE-HD); requirements and test methods
10. DIN EN ISO 15013 (05/99) Extruded sheets made of polypropylene; requirements and test methods
11. DIN 8061 (8/94) Pipes made of plasticizer-free polyvinyl chloride; general quality requirements
12. DIN 8062 (11/88) Pipes made of plasticizer-free polyvinyl chloride; dimensions
13. DIN 8074 (08/99) Pipes made of polyethylene PE 63, PE 80, PE 100, PE-HD; dimensions
14. DIN 8075 (08/99) Pipes made of polyethylene PE 63, PE 80, PE 100, PE-HD; general quality requirements, dimensions
15. DIN 8077 (07/99) Pipes made of polypropylene PP-H 100, PP-B 80, PP-R 80; dimensions

- |     |   |   |
|-----|---|---|
| 16. | DIN 8078 (04/96)<br><br>Part 2 (12/00)            | Pipes made of polypropylene PP-H (Type 1), PP-B (Type 2), PP-R (Type 3); general quality requirements, testing<br>Making test specimens and determining properties                      |
| 17. | DIN 16927 (12/88)                                 | Sheets made of plasticizer-free polyvinyl chloride;<br>technical terms of supply  |
| 18. | DIN 16964 (11/88)                                 | Pipes made of glass-fibre reinforced polyester resins, wound;<br>general quality requirements, testing  |
| 19. | DIN 16965 Part 2 (7/82)                           | Pipes made of glass-fibre reinforced polyester resins, wound, pipe type B,<br>dimensions  |
| 20. | DIN 28051 (07/97)                                 | Chemical apparatus construction – coatings and liners made of<br>organic materials for components made of metal material – design of the<br>metal components                            |
| 21. | DIN 28053 (04/97)                                 | Chemical apparatus construction – coatings and lining with organic<br>materials for components made of metal material; requirements for<br>metal substrates                             |
| 22. | DIN 28055<br><br>Part 1 (04/02)<br>Part 2 (04/02) | Chemical apparatus construction – surface protection with liners made of<br>organic materials for components made of metal material<br>Requirements<br>Proof of suitability and testing |
| 23. | DIN 53766 Part 1 (11/91)                          | Testing apparatuses and tanks made of glass-fibre reinforced plastics;<br>determination of bond strength in the pull-off test   |
| 24. | DIN 53769 Part 1 (11/88)                          | Testing pipes made of glass-fibre reinforced plastics;<br>determination of bond shear strength of pipe components according to pipe type  |
| 25. | DIN 55670 (5/94)                                  | Paints and similar coating materials; testing paintwork,<br>coats and similar coatings for voids and cracks with high voltage   |
| 26. | DIN 65148 (11/86)                                 | Aerospace; testing fibre-reinforced plastics;<br>determination of interlaminar shear strength by tensile test   |
| 27. | DVS 2206 (11/75)                                  | Testing of components and constructions made of thermoplastic materials   |
| 28. | DVS 2207 Part 3 (04/86)                           | Hot-gas welding of thermoplastics, sheets, and pipes.   |
| 29. | DVS 2212 Part 1 (10/94)                           | Examination of plastic welders, examination group I – hot-gas welding with<br>torch separate from filler rod (WF), hot-gas string bead welding (WZ),<br>hot-plate butt welding (HZ)     |
| 30. | NF T 57-900 (12/87)                               | Réservoir et appareils en matières plastiques renforcées<br>Code de construction  |
| 31. | BS 4994 (1987)                                    | Design and construction of vessels and tanks in reinforced plastics<br>The standard applies in conjunction with the 1990 amendment.   |
| 32. | BS 6374 (1985)                                    | Lining of equipment with polymeric material for the process industries<br>Part 1: Spec. for lining with sheet thermoplastic   |